

Argonauts Expanded Description



Designed with state-of-the-art surface mount electronics and proven Doppler technology, SonTek's Argonaut series of acoustic current meters offers unsurpassed accuracy in velocity measurements. Argonauts are available in several configurations for a wide range of applications. A few of the most common are described below.

Open-Ocean Moorings - The Argonaut-MD

The Argonaut-MD (Mooring Deployments) is designed for current monitoring in the open ocean. The Argonaut-MD uses a fixed measurement volume centered 1.25 m from the instrument for 3-MHz systems (2.0 m for 1.5-MHz systems) and is housed in a single canister with internal memory and batteries. The Argonaut-MD can be clamped to the mooring line or mounted within a mooring cage. Low power consumption and flexible sampling strategies allow multiple year deployments using alkaline batteries.

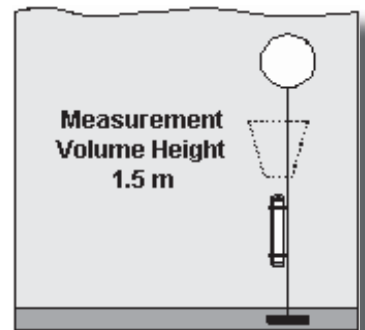

Shallow-Water Deployments - The Argonaut-XR

The Argonaut-XR (Extended Range) is ideal for shallow water current monitoring in areas such as rivers, irrigation channels, estuaries, and ports. Designed for bottom-mounting, the Argonaut-XR has a measurement volume programmable over a vertical range up to 40 m. With the integrated pressure sensor, the Argonaut-XR can adjust the measurement volume height to report depth-averaged velocity over the entire water column or over a user-programmable range (even with tide or stage variation). The Argonaut-XR can be used for real-time monitoring (cable lengths up to 1500 m) or autonomous deployments with the external battery pack.

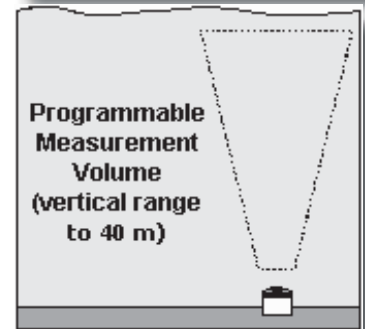

Underwater Structures - The Argonaut-SL

The Argonaut-SL (Side-Looking) is designed for horizontal operation, making a remote velocity measurement from an underwater structure (pier, bridge, channel, etc.) while allowing a simple and secure instrument mounting. The Argonaut-SL measures 2D currents in an adjustable measurement volume located at a range up to 22 m. Like the Argonaut-XR, the Argonaut-SL can be used for real-time or autonomous applications.

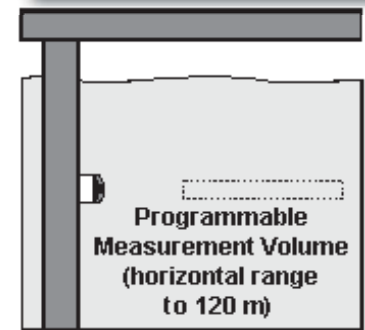

How Argonauts Work

The Argonauts belong to a class of instruments known as monostatic Doppler current meters. Monostatic refers to the fact that the same transducer is used as transmitter and receiver. A monostatic Doppler uses a set of acoustic transducers with precisely known relative orientations. Each transducer produces a narrow beam of sound perpendicular to the transducer face. The operation of a 3D Argonaut (with three transducers) is shown here.

SonTek/YSI, founded in 1992 and advancing environmental science in over 100 countries, manufactures affordable, reliable acoustic Doppler instrumentation for water velocity measurement in oceans, rivers, lakes, harbors, estuaries, and laboratories. Headquarters are located in San Diego, California.

During operation, each transducer produces a short pulse of sound at a known frequency that propagates along the axis of the acoustic beam. Sound from the outgoing pulse is reflected ("scattered") in all directions by particulate matter in the water. Some portion of the scattered energy travels back along the beam axis to the transducer. This return signal has a frequency shift proportional to the velocity of the scattering material. This frequency change (Doppler shift), as measured by the Argonaut, is proportional to the projection of the water velocity onto the axis of the acoustic beam. By combining data from three beams, and knowing the relative orientation of those beams, the Argonaut measures the 3D velocity. In the same manner, the Argonaut-SL measures 2D velocity in the plane defined by its two acoustic beams.

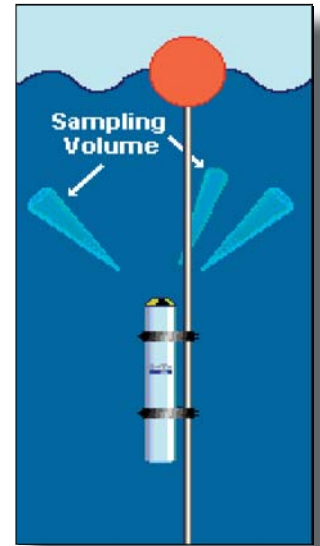

Argonaut Advantages

Doppler technology has several inherent advantages that make it the preferred method for current measurement. Combining this with SonTek's proven ability to develop instruments that are both powerful and easy to use, the Argonaut is the ideal choice for a wide range of applications. Argonaut advantages include:

- Measurements are made in a remote sampling volume free from flow distortion.
- Velocity data are free from drift; the Argonaut never requires calibration.
- Doppler technology has no inherent minimum detectable velocity, giving excellent performance at low flows.
- The Argonaut has no moving parts, is immune to biofouling contamination, and the user can directly apply anti-fouling paint to prevent growth.
- The same robust computational algorithms are used for velocities from 1 cm/s to 10 m/s.

SonTek's user interface allows easy operation with minimal training and experience. First time users can collect test data within minutes of receiving the Argonaut. Deployments require only a few minutes to configure the Argonaut and start collecting data. The basic operating parameters include the following: averaging time, time between samples, and start time. The Argonaut provides the highest quality Doppler velocity data without requiring the user to become an expert on Doppler technology.

Argonaut Performance Verification

Argonaut velocity data has a specified accuracy of $\pm 1\%$ of measured velocity and ± 0.5 cm/s. These specifications have been verified using laboratory simulations, tow-carriage testing, and field comparisons with other meters. Results from one tow-carriage test are presented here.

An Argonaut was mounted from the bottom of a moving carriage at the Offshore Model Basin (OMB) tow facility in Escondido, California. The meter was towed over a working tank length of 45 m at eight speeds in both directions. Two different mounting orientations were used with no effect on velocity performance. Tow carriage speed at OMB has been independently verified to $\pm 0.5\%$. Results from all runs are shown in the plot below. A least squares linear fit of the velocity data to the carriage speed gives a slope of 0.996 with an offset of 0.1 cm/s.

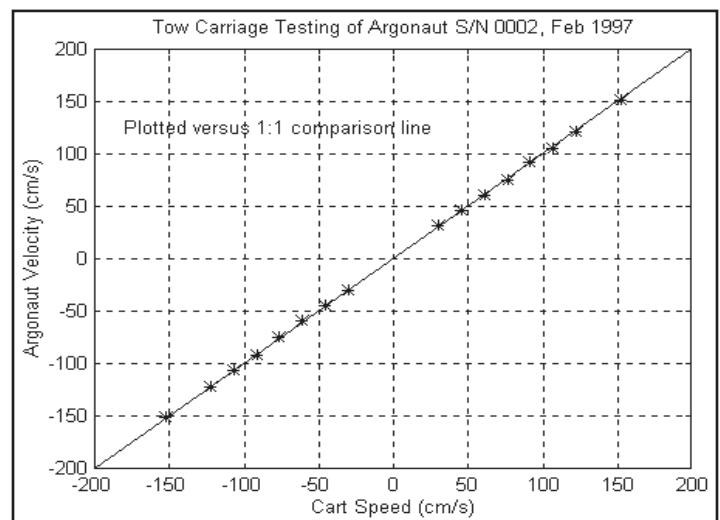

SonTek/YSI
9940 Summers Ridge Road
San Diego, CA 92121
Tel: +1 858 546 8327
Fax: +1 858 546 8150
Email: inquiry@sontek.com
Web: www.ysi.com

